



## **INTRODUCING HMI**

The Hoist Manufacturer's Institute (HMI), an affiliate of Material Handling Industry, is a trade association of manufacturers of overhead handling hoists. The products of its member companies include hand chain hoists, ratchet lever hoists, trolleys, air chain and air rope hoists, and electric chain and electric wire rope hoists.

HMI operates through committees with programs and policies reviewed and adopted by the membership with representation from each member company. HMI is represented on a number of standards developing committees and actively supports the development and certification of safety standards by the ANSI consensus method.

HMI member companies are concerned, conscientious manufacturers affiliated in an industry association to provide voluntary standards for the mechanical, structural and electrical design of hand chain hoists, ratchet lever hoists, trolleys, air chain and air rope hoists, and electric chain and electric wire rope hoists and to formulate guidelines for the proper use, operation and maintenance of that equipment.

Hoist Manufacturers Institute  
8720 Red Oak Boulevard  
Suite 201  
Charlotte, NC 28217-3992  
Ph.: (704) 676-1190  
Fax: (704) 676-1199  
<http://www.mhia.org/hmi>



## **MEMBERS\* of the HOIST MANUFACTURERS INSTITUTE**

Acco Chain & Lifting Products  
P.O. Box 792  
York, PA 17405-0792  
(800) 967-7333  
[www.accolifting.com](http://www.accolifting.com)

Ace World Companies, Inc.  
10200 Jacksboro Hwy.  
Fort Worth, TX 76135  
(817) 237-7700  
[www.aceworldcompanies.com](http://www.aceworldcompanies.com)

Chester Hoist, Inc.  
P.O. Box 449  
Lisbon, OH 44432  
(330) 424-7248  
[www.chesterhoist.com](http://www.chesterhoist.com)

Coffing Hoists  
9415 Pioneer Avenue  
P.O. Box 411245  
Charlotte, NC 28273  
(704) 916-5501  
[www.coffinghoists.com](http://www.coffinghoists.com)

Columbus McKinnon Corporation (CM)  
140 John James Audubon Parkway  
Amherst, NY 14228-1197  
(716) 689-5400  
[www.cmworks.com](http://www.cmworks.com)

Demag Cranes and Components Corporation  
29201 Aurora Road  
Solon, OH 44139-1895  
(440) 248-2400  
[www.demag-us.com](http://www.demag-us.com)

Electro Lift Inc.  
204 Sargeant Avenue  
Clifton, NJ 07013  
(973) 471-0204  
[www.electrolift.com](http://www.electrolift.com)

Harrington Hoists Inc.  
401 West End Avenue  
Manheim, PA 17545  
(717) 665-2000  
[www.harringtonhoists.com](http://www.harringtonhoists.com)

Ingersoll-Rand Company  
P.O. Box 970  
Annandale, NJ 08801  
(908) 238-7000  
[www.irhoist.com](http://www.irhoist.com)

J.D. Neuhaus L.P.  
9 Loveton Circle  
Sparks, MD 21152  
410-472-0500  
[www.jdneuhaus.com](http://www.jdneuhaus.com)

Lift-Tech International, a division of Columbus  
McKinnon Corporation  
P.O. Box 769  
Muskegon, MI 49443-0769  
(231) 733-0821  
[www.cmworks.com](http://www.cmworks.com)

Morris Material Handling, LLC  
315 West Forrest Hill Avenue  
Oak Creek, WI 53154  
(414)764-6200  
[www.morriscranes.com](http://www.morriscranes.com)

R & M Materials Handling Inc.  
4501 Gateway Blvd.  
Springfield, OH 45502-9339  
(937) 328-5100  
[www.rmhoist.com](http://www.rmhoist.com)

R. Stahl, Inc.  
6420 Dorchester Road  
Charleston, SC 29418  
843-767-1951  
[www.stahlus.com](http://www.stahlus.com)

Ratcliff Hoist Company, Inc.  
1655 Old County Road  
San Carlos, CA 94070  
(650) 595-3840  
[beratcliff@yahoo.com](mailto:beratcliff@yahoo.com)

Saturn Engineering Corporation  
10 Main Street  
Newark, NJ 07105  
(973) 465-0224  
[www.saturneng.com](http://www.saturneng.com)

# **Manually Lever Operated Hoist Inspection and Hoist Maintenance Personnel Manual**

**Prepared and Published by**



HOIST MANUFACTURERS INSTITUTE<sup>SM</sup>

**8720 Red Oak Blvd., Suite 201  
Charlotte, NC 28217-3992**

**© 2003 Hoist Manufacturers Institute  
All Rights Reserved**

# TABLE OF CONTENTS

---

|   |    |
|---|----|
| INTRODUCTION AND DISCLAIMER   | 3  |
| MANUALLY LEVER OPERATED HOIST TYPES   | 9  |
| TENSIONING MEDIUM TYPES   | 9  |
| MANUALLY LEVER OPERATED OPERATION TYPES   | 10 |
| INSPECTION PROCEDURES AND MAINTENANCE   | 13 |
| MANUALLY LEVER OPERATED HOIST INSPECTION AND<br>MAINTENANCE PERSONNEL RESPONSIBILITIES AND REQUIREMENTS | 15 |
| DAILY OR PRESTART HOIST INSPECTIONS   | 16 |
| FREQUENT AND PERIODIC HOIST INSPECTIONS   | 18 |
| HOIST INSPECTION REPORTS  | 26 |
| HOOK INSPECTION   | 27 |
| WIRE ROPE INSPECTION  | 30 |
| LOAD CHAIN INSPECTION   | 36 |
| WEB STRAP INSPECTION  | 41 |
| LOAD CONTROLLING MECHANISM – HOIST BRAKING<br>SYSTEM / RATCHET AND PAWL INSPECTION                      | 42 |
| HOIST TESTING   |    |
| APPENDIX A:<br>DEFINITIONS OF VARIOUS HOIST TERMS   | 44 |
| APPENDIX B:<br>HOIST REFERENCE DOCUMENTS AND STANDARDS  | 47 |
| APPENDIX C:<br>HOIST INSPECTION REPORT FORMS (L1 THROUGH L6)  | 48 |

## **INTRODUCTION AND DISCLAIMER**

---

The Hoist Manufacturers Institute (HMI) is an independent incorporated trade association affiliated with the Material Handling Industry of America Division of Material Handling Industry (MHI).

### **MATERIAL HANDLING INDUSTRY AND ITS MATERIAL HANDLING INDUSTRY OF AMERICA DIVISION**

MHI provides HMI with certain services and, in connection with this Manually Lever Operated Hoist Inspection and Hoist Maintenance Personnel Manual, arranges for its production and distribution. Neither MHI, its officers, directors, employees nor members have any other participation in the development and preparation of the information contained in this Manual.

All inquiries concerning this Manually Lever Operated Hoist Inspection and Hoist Maintenance Personnel Manual should be directed in writing to the Chairman of the HMI Engineering Committee, c/o Hoist Manufacturers Institute, 8720 Red Oak Boulevard, Suite 201, Charlotte, North Carolina, 28217-3992.

### **MANUALLY LEVER OPERATED HOIST INSPECTION AND MAINTENANCE PERSONNEL MANUAL**

This Manual has been prepared by HMI and its Engineering Committee with the sole intent of offering information and suggestions to parties engaged with Manually Lever Operated Hoist Inspection and Maintenance Personnel in their inspection and maintenance of manually lever operated hoists. This Manual is advisory only and should be regarded as a guide that the user may or may not choose to adopt, modify or reject. The information does not constitute a comprehensive safety program and should not be relied upon as such. Such a program should be developed and an independent safety adviser consulted to do so. At times, hoist inspection and maintenance personnel may be required to operate a manually lever operated hoist in the performance of their inspection and maintenance duties. Operation of a manually lever operated hoist involves more than operating the controls of the hoist. The operator must consider and anticipate the motions, actions, and loads that will occur as a result of operating the hoist. Therefore, it is important for the Manually Lever Operated Hoist Inspection and Maintenance Personnel to be instructed in the operation of manually lever operated hoists and to understand the severe consequences that may result from careless operation. Refer to the Manually Lever Operated Hoist Operators Manual, latest edition, published by HMI.

## INTRODUCTION AND DISCLAIMER

---

The acceptance or use of this Manual is completely voluntary. Its existence does not preclude anyone from using information not conforming to it. It is not intended that the recommendations in this Manual take precedence over existing plant safety rules and regulations, OSHA regulations, or instructions issued by the manufacturer of the manually lever operated hoist. However, a thorough study of the following information should provide a better understanding of safe operation and afford a greater margin of safety for people and machinery on the plant floor.

It must be recognized that this is a Manual of recommendations for the Manually Lever Operated Hoist Inspection and Maintenance Personnel and its use is permissive not mandatory. It is the responsibility of the owner of the hoist to make personnel aware of all federal, state and local rules, codes and plant safety rules and regulations and instructions and to make certain operators and inspection and maintenance personnel are properly trained.

### DISCLAIMERS AND INDEMNITY

**DISCLAIMER OF LIABILITY:** MHI, HMI AND THEIR SUCCESSORS, ASSIGNS, OFFICERS, AGENTS, EMPLOYEES AND THEIR MEMBERS ASSUME NO RESPONSIBILITY AND DISCLAIM ALL LIABILITY OF ANY KIND, HOWEVER ARISING, AS A RESULT OF ACCEPTANCE OR USE OR ALLEGED USE OF THIS MANUAL. USER SPECIFICALLY UNDERSTANDS AND AGREES THAT MHI AND HMI AND THEIR SUCCESSORS, ASSIGNS, OFFICERS, AGENTS, EMPLOYEES AND MEMBERS SHALL NOT BE LIABLE UNDER ANY LEGAL THEORY OF ANY KIND FOR ANY ACTION OR FAILURE TO ACT WITH RESPECT TO THE RECOMMENDED OPERATIONS OR ANY OTHER THING COVERED BY THIS MANUAL.

**DISCLAIMER OF WARRANTY:** MHI, HMI MAKE NO WARRANTIES OF ANY KIND, EXPRESS, IMPLIED, OR STATUTORY, IN CONNECTION WITH THE INFORMATION IN THIS MANUAL. MHI AND HMI SPECIFICALLY DISCLAIM ALL IMPLIED WARRANTIES OF MERCHANTABILITY OR OF FITNESS FOR PARTICULAR PURPOSE.

## INTRODUCTION AND DISCLAIMER

---

**INDEMNITY:** BY REFERRING TO OR OTHERWISE EMPLOYING THIS MANUAL, THE USER AGREES TO DEFEND, PROTECT, INDEMNIFY, AND HOLD MHI AND HMI AND THEIR OFFICERS, AGENTS, EMPLOYEES AND MEMBERS HARMLESS FROM AND AGAINST ALL CLAIMS, LOSSES EXPENSES, DAMAGES, AND LIABILITIES, DIRECT, INCIDENTAL, OR CONSEQUENTIAL, ARISING FROM ACCEPTANCE OR USE OR ALLEGED ACCEPTANCE OR USE OF THIS MANUAL, INCLUDING LOSS OF PROFITS AND REASONABLE ATTORNEYS' FEES WHICH MAY ARISE OUT OF THE ACCEPTANCE OR USE OR ALLEGED ACCEPTANCE OR USE OF THIS MANUAL. THE INTENT OF THIS PROVISION AND OF THE USER IS TO ABSOLVE AND PROTECT MHI AND HMI AND THEIR OFFICERS, AGENTS, EMPLOYEES AND MEMBERS FROM ANY AND ALL LOSS RELATING IN ANY WAY TO THIS MANUAL, INCLUDING THOSE RESULTING FROM THE USER'S OWN NEGLIGENCE.

**Taking precedence over any specific rule,  
however, is the most important rule of all:**

**“USE COMMON SENSE.”**

It is a responsibility of the manually lever operated hoist owner/user to establish programs to:

1. train and designate hoist operators, and
2. train and designate hoist inspection and maintenance personnel.

The words **shall** and **should** are used throughout this Manual in accordance with definitions in the ASME B30 standards as follows:

**shall** this word indicates that a rule is mandatory and must be followed.

**should** this word indicates that a rule is a recommendation, the advisability of which depends on the facts in each situation.

## INTRODUCTION AND DISCLAIMER

---

Manually Lever Operated Hoist Operator and Inspection and Maintenance Personnel training programs should be based on requirements in accordance with the latest edition of:

- ASME B30.21 Safety Standard for Manually Lever Operated Hoists

Such training programs should also provide information for compliance with any Federal, State, or Local Code requirements, existing plant safety rules and regulations, and the instructions furnished by the manufacturer of the hoist.

If a manually lever operated hoist is installed as part of an overhead crane or monorail system, reference should also be made to the latest edition for the following HMI publications:

- Hoist Operators Manual
- Hoist Inspection and Hoist Maintenance Personnel Manual

### **NOTICE**

IT IS A RESPONSIBILITY OF THE OWNER/USER TO INSTALL, INSPECT, TEST, MAINTAIN, AND OPERATE A MANUALLY LEVER OPERATED HOIST IN ACCORDANCE WITH THE ASME B30.21 SAFETY STANDARD AND OSHA REGULATIONS. IF THE HOIST IS INSTALLED AS PART OF A TOTAL LIFTING SYSTEM, IT IS ALSO THE RESPONSIBILITY OF THE OWNER/USER TO COMPLY WITH THE APPLICABLE ASME B30 VOLUME THAT ADDRESSES OTHER TYPES OF EQUIPMENT USED IN THE SYSTEM.

FURTHER, IT IS THE RESPONSIBILITY OF THE OWNER/USER TO REQUIRE THAT ALL PERSONNEL THAT WILL INSTALL, INSPECT, TEST, MAINTAIN, AND OPERATE A MANUALLY LEVER OPERATED HOIST READ THE CONTENTS OF THE INSTRUCTION MANUAL FURNISHED BY THE MANUFACTURER OF THE HOIST, ASME B30.21 SAFETY STANDARD FOR MANUALLY LEVER OPERATED HOISTS, AND OSHA REGULATIONS. IF THE HOIST IS INSTALLED AS PART OF A TOTAL LIFTING SYSTEM, THE APPLICABLE ASME B30 VOLUME THAT ADDRESSES OTHER TYPES OF EQUIPMENT USED IN THE SYSTEM MUST ALSO BE READ BY ALL PERSONNEL.



## INTRODUCTION AND DISCLAIMER

---

### SAFETY ALERT SYMBOL

The Safety Alert Symbol is used in this Manual to indicate hazards and to alert the reader to information that should be known, understood, and followed in order to avoid DEATH or SERIOUS INJURY.

Read and understand this Manual before using, inspecting,  
or maintaining the manually lever operated hoist.

Important issues to remember during operation are provided in the hoist control stations at various locations on the hoist and in the manuals by **DANGER**, **WARNING**, or **CAUTION** instructions or placards, that alert personnel to potential hazards, proper operation, load limitations, and more.



#### **DANGER**

Indicates an imminently hazardous situation which, if not avoided, will result in death or serious injury.



#### **WARNING**

Indicates a potentially hazardous situation which, if not avoided, could result in death or serious injury.



#### **CAUTION**

Indicates a potentially hazardous situation which, if not avoided, may result in minor or moderate injury. It may also be used to alert against unsafe practices.

## INTRODUCTION AND DISCLAIMER

---

### **⚠ WARNING**

FAILURE TO READ AND COMPLY WITH ANY ONE OF THE LIMITATIONS NOTED IN THIS MANUAL AND THE INSTRUCTION MANUAL FURNISHED BY THE MANUFACTURER OF THE HOIST CAN RESULT IN SERIOUS BODILY INJURY OR DEATH, AND/OR PROPERTY DAMAGE.

### **⚠ WARNING**

BEFORE INSTALLING, REMOVING, INSPECTING, OR PERFORMING ANY MAINTENANCE ON A MANUALLY LEVER OPERATED HOIST, MAKE CERTAIN THE LOAD HAS BEEN PARKED AND REMOVED FROM THE HOIST. FOLLOW OTHER MAINTENANCE PROCEDURES OUTLINED IN THE MANUAL FURNISHED BY THE MANUFACTURER OF THE HOIST AND ASME B30.21.

Because the manufacturer of the lever operated hoist has no direct involvement or control over the manually lever operated hoist's operation and application, conforming to good safety practices is the responsibility of the owner, the user, and its operating personnel.

Only those Authorized and Qualified Personnel who have shown that they have read and have understood this Manual and the manufacturer's manual and that they understand the proper operation and maintenance of the hoist should be permitted to operate and/or maintain the hoist.

## **PLACARDS AND INSTRUCTIONS**

READ and OBEY all Danger, Warning, Caution, and Operating Instructions on the hoist and in all manufacturers' manuals and this Manual. Make sure that all placards are in place and legible.

Failure to comply with safety precautions in this Manual, in the manufacturer's manual and on the hoist maybe a safety violation that may result in serious injury, death, or property damage.

## MANUALLY LEVER OPERATED HOIST TYPES

---

Manually lever operated hoists are defined in ASME B30.21 as a lever operated manual device used to lift, lower, or pull a load and to apply or release tension. Lever operated hoists are a basic and versatile piece of equipment used in manufacturing, warehousing, construction, and numerous other applications to aid workers in the handling, moving, and tensioning of loads.

Manually lever operated hoists are generally available in three types as defined by the medium used to tension or move the load. The three types are chain, wire rope, and web strap. All three types share in common the features of a hook at the hoist frame, a hook at the load block and a lever to apply a load between the two hoist hooks. These three types may use ratchet and pawl or friction brake operating mechanisms and are illustrated in Figure 1 on page 12.

Chain type — uses welded link load chain or roller chain as a tensioning medium

Wire rope type — uses wire rope (cable) as a tensioning medium

Web strap type — uses a web strap of nylon, polyester, or similar synthetic material as a tensioning medium

### LEVER OPERATED HOIST TENSIONING MEDIUM TYPES

- Welded Link Load Chain
- Roller Load Chain
- Wire Rope
- Web Strap

#### WELDED LINK LOAD CHAIN

Welded link load chain consists of a series of interwoven formed and welded links. The links fit pockets of the hoist load sprocket that transmits motion to the load chain. The load sprocket may also be called load wheel, load sheave, pocket wheel, chain wheel, or lift wheel. Welded link load chain sizes are stated as the diameter of the wire used to form the link, i.e. 1/4 in., 5/16 in., etc. Welded link load chain is designed and manufactured to specific dimension and material strength requirements for a specific hoist. Welded link load chain is **not interchangeable** between different manufacturers' hoists; and is **not interchangeable** with welded link lifting chain used for other purposes such as chain slings and load securement. Only welded link load chain with specifications as originally stated by the hoist manufacturer should be used on any welded link load chain hoist.

## **MANUALLY LEVER OPERATED HOIST TYPES**

---

### **ROLLER LOAD CHAIN**

Roller load chain consists of a series of alternately assembled roller links and pin links where the pins articulate inside bushings and the rollers are free to turn on the bushings. Pins and bushings are press fit in their respective link plates. The links fit teeth of the hoist load sprocket that transmits motion to the load chain. The load sprocket may also be called load wheel, load sheave, chain wheel, or lift wheel. Roller load chain sizes are stated as the pitch or spacing between pins, i.e. 5/8 in., 3/4 in., etc. Roller load chain for use on hoists is designed and manufactured to specific material strength requirements for hoist applications. Roller load chain for hoist applications has different manufacturing specifications than roller chain for power transmission applications. Therefore, hoist roller load chain is not interchangeable with power transmission roller chain. Only roller load chain with specifications as originally stated by the hoist manufacturer should be used on any roller load chain hoist.

### **WIRE ROPE**

Wire rope consists of a core, strands, and wires that comprise a strand. The wire rope fits and wraps onto grooves on the circumference of the hoist drum that transmits motion to the wire rope. Wire rope sizes are stated as the diameter of a circle that would enclose the wire rope strands, i.e. 5/16 in., 3/8 in., etc. Each wire rope size is available in various rope constructions and materials. The construction and material strength requirements of the wire rope are selected by the hoist manufacturer in accordance with the design specification requirements of the hoist. Therefore, only wire rope with specifications as originally stated by the hoist manufacturer should be used on any wire rope hoist.

### **WEB STRAP**

Web strap consists of nylon or polyester (or other synthetic) woven material. The web strap fits and wraps onto the circumference of the drum that transmits motion to the web strap. Web strap sizes are stated as the material width. Each web strap size is available in various constructions and materials. The construction and material strength requirements of the web strap are selected by the hoist manufacturer in accordance with the design specification requirements of the hoist. Therefore, only web strap with specifications as originally stated by the hoist manufacturer should be used on any web strap hoist.

## MANUALLY LEVER OPERATED HOIST TYPES

---

### LEVER OPERATED HOIST OPERATION TYPES

As previously stated, operation defines the type of mechanism used to apply the load. Operation types include:

- Ratchet and pawl operation
- Friction brake operation

Ratchet and pawl type manually lever operated hoists operate using a ratchet which is driven by the lever. The ratchet is integral or attached to a pocket wheel for chain type hoists or a drum for wire rope and web strap type. The ratchet is typically controlled by a driving pawl and a holding pawl. The driving pawl is driven by the lever and imparts motion to the ratchet which tensions or releases the load with the load alternately coming to rest on the holding pawl when the lever is released by the operator. A directional lever or switch permits the operator to select tension or release (directions). Successive repeated operation of the lever serves to either apply more tension or release tension until the load tension is zero.

Friction brake type manually lever operated hoists operate by using a brake mechanism which may be directly connected or connected via a gear train to a pocket wheel for chain type hoists or a drum for wire rope and web strap type. The lever drives the locked brake over a one way ratchet mechanism thus imparting tension to the chain wire rope or web strap. To release tension, the lever driving direction is reversed and the lever force applied to open the brake which allows the load to release in a controlled manner. When the lever force is released the brake automatically closes in response to the load. Successive repeated operation of the lever serves to either apply more tension or release tension until the load tension is zero.

# MANUALLY LEVER OPERATED HOIST TYPES

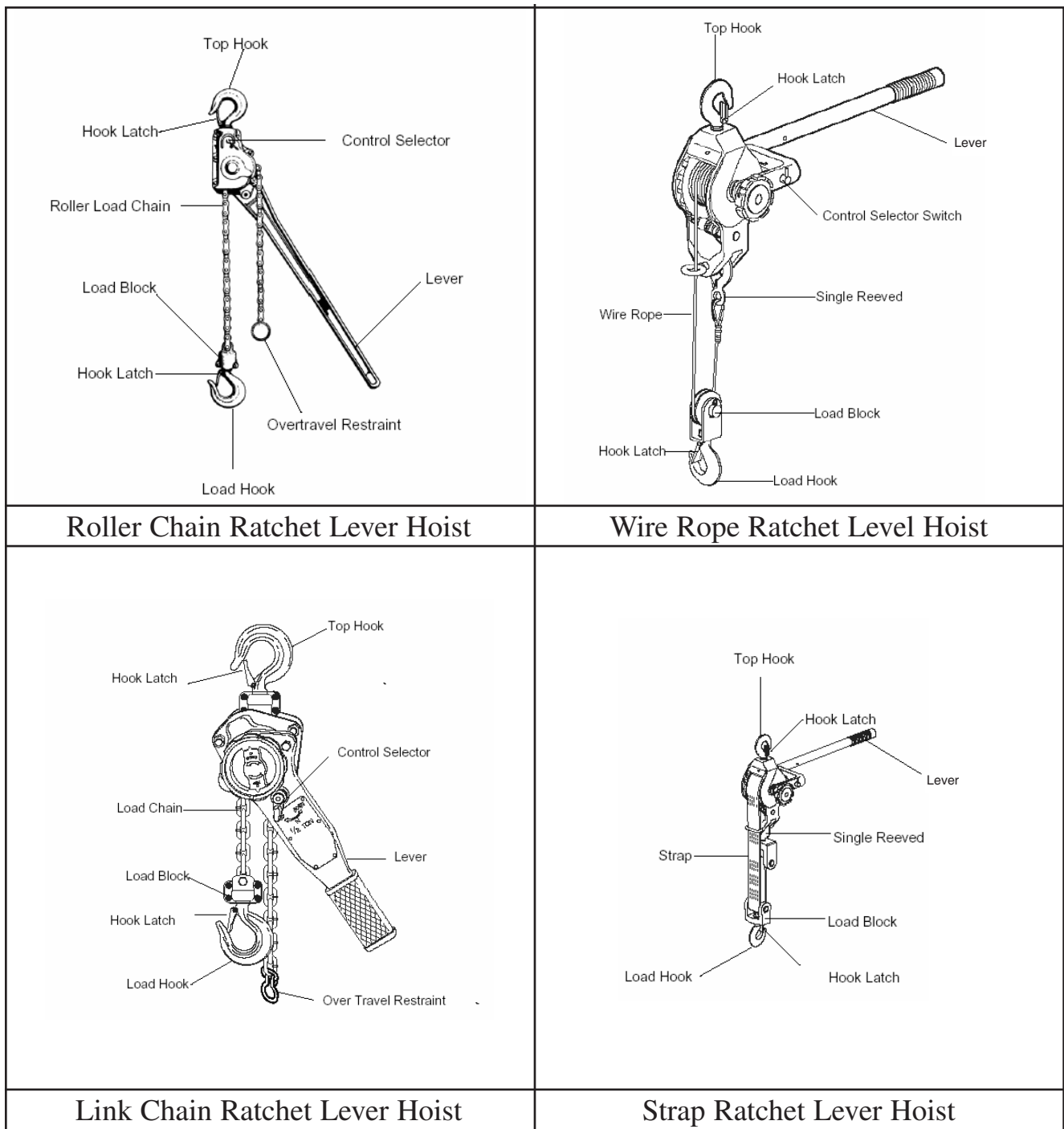

FIGURE 1  
Principal Parts of Manually Operated Lever Hoists

## **MANUALLY LEVER OPERATED HOIST INSPECTION AND MAINTENANCE PROCEDURES**

---

Manually lever operated hoist inspection, maintenance, and repair can be performed in various ways depending on the conditions, policies, and practices of a particular owner/user. Maintenance policies and practices are determined by the size of the operation and number of employees, the availability of trained and experienced in-house maintenance persons, and the type of hoists.

Regardless of the manner used to perform manually lever operated hoist inspections, maintenance, and repairs, each function should be performed only by trained, experienced, and qualified hoist inspection, maintenance, and repair personnel. For information on hoist inspection, maintenance, and repair, always refer to the manual furnished by the manufacturer of the hoist.

### **NOTICE**

THE HOIST OPERATOR SHOULD NOT PERFORM FREQUENT AND PERIODIC INSPECTIONS, MAINTENANCE, OR REPAIR ON A MANUALLY LEVER OPERATED HOIST, UNLESS THE OPERATOR HAS BEEN TRAINED TO PERFORM SUCH INSPECTIONS, MAINTENANCE, OR REPAIR ON A MANUALLY LEVER OPERATED HOIST AND IS DESIGNATED BY THE HOIST OWNER/USER TO PERFORM SUCH INSPECTIONS, MAINTENANCE, AND REPAIR.

### **MAINTENANCE AND INSPECTION PROCEDURES**

Manually lever operated hoists shall be maintained, inspected, and tested in accordance with the manual furnished by the manufacturer of the hoist and in accordance with the intervals and requirements of ASME B30.21.

Before maintenance or inspections are performed on a manually lever operated hoist, precautions shall be taken, which include those listed and recommended below. While the hoist operator should not perform inspection, maintenance, or repair on a hoist, unless trained, qualified, and authorized to do so, the operator may be involved in performing these precautions before maintenance or inspections are performed by others.

## MAINTENANCE AND INSPECTION PROCEDURES

1. If a load is attached to the manually lever operated hoist, it should be landed. On all manually lever operated hoists, the load block should be lowered onto a surface that allows the lifting medium to be slackened.
2. If the hoist is suspended from a fixed location, maintenance and inspections can be performed in place, or the hoist can be removed to a repair area as required.
3. If maintenance or inspection is carried out while the hoist is suspended from a fixed location, warning signs and barriers should be utilized on the floor beneath the hoist, if work creates a hazardous area on the floor beneath the hoist.
4. Safe access to the manually lever operated hoist, such as scaffolding, work platforms, etc., should be provided, as necessary, for personnel that will perform maintenance, repair, or inspection. If personnel are required to work above floor or ground level, a fall prevention policy and procedure shall be developed, documented, and implemented by the owner/user.
5. After maintenance, repair, or inspection work is completed, and before the hoist is returned to normal operation:
  - Any guards and covers on the hoist that were removed to perform maintenance, repair, or inspection work shall be reinstalled.
  - Any safety devices on the hoist or surrounding area that were deactivated to perform maintenance, repair, or inspection work shall be reactivated.
  - Any parts that were replaced and other loose material shall be removed.
  - All equipment used in the maintenance, repair, or inspection work shall be removed.
6. Warning signs, barriers, and guards shall be removed only by authorized personnel.
7. If the extent of the maintenance or repair work requires any testing as outlined in ASME B30.21 or any other applicable ASME B30 volume; such tests shall be conducted before the manually lever operated hoist is returned to normal operation.



**MANUALLY LEVER OPERATED HOIST INSPECTION AND MAINTENANCE PERSONNEL RESPONSIBILITIES AND REQUIREMENTS**

**IT IS RECOMMENDED THAT MANUALLY LEVER OPERATED HOIST INSPECTION AND MAINTENANCE PERSONNEL SHALL:**

Be required to read the operation, inspection, and maintenance sections of the manual furnished with the hoist.

Be required to read the warnings in the manual furnished with the hoist.

Be required to read the instructions and warning labels on the hoist.

Be required to read the operation, inspection, and maintenance sections of ASME B30.21.

Be required to be familiar with the hoist controls before being authorized to operate the hoist.

Have normal depth perception, field of vision, reaction time, manual dexterity, and coordination for the work to be performed.

**NOT** be subject to seizures, loss of physical control, physical defects, or emotional instability that could result in actions of the operator being a hazard to the operator or others.

**NOT** operate a hoist when under the influence of alcohol or drugs.

**NOT** operate a hoist when under the influence of medication that could result in actions of the operator being a hazard to the operator or others.

**NOTICE**

MANUALLY LEVER OPERATED HOISTS ARE INTENDED ONLY FOR MOVING OR TENSIONING OF FREE UNGUIDED LOADS. DO NOT USE A HOIST TO MOVE OR TENSION LOADS THAT ARE NOT LIFTED VERTICALLY, LOADS THAT ARE NOT FREE OR THAT ARE GUIDED. IF SUCH CONDITIONS EXIST, THE OPERATOR SHOULD CONTACT THE SUPERVISOR FOR INSTRUCTIONS.

**⚠ WARNING**

DO NOT LIFT PERSONNEL.  
DO NOT LIFT LOADS OVER PEOPLE.

## MANUALLY LEVER OPERATED HOIST INSPECTIONS

---

### DAILY OR PRESTART HOIST INSPECTIONS

In accordance with the requirements of ASME B30.21 the hoist operator should perform daily (prestart) inspections at the start of each shift, or at the time the hoist is first used during each shift. The daily inspection is a visual and audible examination of the hoist. Records of the daily inspection are not required except as required by the hoist owner/user. Daily inspection items that should be performed by the operator at the start of each shift, or at the time the hoist is first used during each shift, include the following outlined in Table 1.

**TABLE 1**  
**MANUALLY LEVER OPERATED HOISTS**  
**DAILY INSPECTION**  
**(REFER ALSO TO THE MANUAL FURNISHED BY THE HOIST MANUFACTURER)**

| <b><u>INSPECTION ITEM</u></b> | <b><u>DESCRIPTION OF INSPECTION CHECK POINTS</u></b>   |
|-------------------------------|--|
| Tagged Hoist                  | Check that hoist is not tagged with an out-of-order sign.  |
| All Functional Mechanisms     | Check for proper operation and adjustment.   |
| Controls                      | Check that all direction motions agree with directional selection setting when lever is actuated.  |
| Hook                          | Check for damage, cracks, nicks, gouges, deformation of the throat opening, wear on the saddle or load bearing point, and twist.   |
| Hook Latch                    | Check that hook latch, if provided, is not missing and that it operates properly.  |
| Operating Lever               | Check for bends, cracks, and other damage.   |
| Tensioning Medium – Chain     | Check for nicks, gouges, and any type of deformation or damage to the chain. Check for proper lubrication of load chain.   |
| Wire Rope                     | Check for distortion, kinking, crushing, unstranding, birdcaging, main strand displacement and core protrusion; general corrosion; broken and cut strands; number, distributions and type of visible broken wires (12 randomly distributed broken wires in one lay or four broken wires in one strand and one outer wire broken at the contact point with the core which has worked its way out and protrudes or loops out is cause for removal from service). |

## MANUALLY LEVER OPERATED HOIST INSPECTIONS

---

**TABLE 1**  
**MANUALLY LEVER OPERATED HOISTS**  
**DAILY INSPECTION (CONTINUED)**  
**(REFER ALSO TO THE MANUAL FURNISHED BY THE HOIST MANUFACTURER)**

| INSPECTION ITEM                   | DESCRIPTION OF INSPECTION CHECK POINTS  |
|-----------------------------------|---|
| Web Strap                         | Check for gross damage from melting and charring; acid or caustic burns; weld spatter; broken stitching; cuts or tears; damaged eyes or fittings; abrasive wear; and knots. |
| Reeving                           | Check that tensioning medium is properly reeved and that it is not kinked or twisted, and that parts are not twisted about each other.                                      |
| Brakes (if equipped)              | Check that hoist motion does not have excessive drift and that stopping distance is normal.   |
| Ratchet and Pawl<br>(if equipped) | Check for proper operation of springs and pawls. Make sure pawls operate freely and that load is controlled during operation.   |
| Oil or Grease Leakage             | Check for any sign of oil or grease leakage on the hoist.   |
| Unusual Sounds                    | Check for any unusual sounds from the hoist and hoist mechanism while operating the hoist.  |
| Warning and Safety Labels         | Check that warning and other safety labels are not missing and that they are legible.   |

### **⚠ WARNING**

IF ANY DAMAGE OR MALFUNCTIONS ARE NOTED BY THE DAILY INSPECTION ITEMS, THE OPERATOR SHALL NOT OPERATE THE LEVER HOIST, AND SHALL IMMEDIATELY ADVISE THE SUPERVISOR SO CORRECTIVE ACTION CAN BE TAKEN. IF THE HOIST IS TAGGED WITH AN OUT-OF-ORDER SIGN, THE OPERATOR SHALL NOT OPERATE THE HOIST.

LEVER HOIST OPERATORS SHOULD BE AWARE OF MALFUNCTIONS OF THE EQUIPMENT THAT COULD OCCUR DURING OPERATION, AND SHOULD IMMEDIATELY STOP OPERATION IF SUCH MALFUNCTIONS OCCUR, AND SHOULD IMMEDIATELY ADVISE THE SUPERVISOR SO CORRECTIVE ACTION CAN BE TAKEN.

## MANUALLY LEVER OPERATED HOIST INSPECTIONS

---

### FREQUENT AND PERIODIC MANUALLY LEVER OPERATED HOIST INSPECTIONS

Frequent and periodic inspections of the hoist in accordance with the requirements of the ASME B30.21 standard and as outlined in the manual furnished by the hoist manufacturer are required.

Frequent and periodic inspections are to be performed by trained, experienced, and qualified hoist inspection and hoist maintenance personnel.

Refer to the FREQUENT AND PERIODIC HOIST INSPECTIONS section of this manual.

### **NOTICE**

THE LEVER HOIST OPERATOR SHALL NOT PERFORM FREQUENT OR PERIODIC INSPECTIONS, OR PERFORM MAINTENANCE ON A HOIST UNLESS THE OPERATOR HAS BEEN TRAINED TO PERFORM SUCH INSPECTIONS OR MAINTENANCE, AND IS DESIGNATED BY THE HOIST OWNER/USER TO PERFORM SUCH INSPECTIONS OR MAINTENANCE.

## FREQUENT AND PERIODIC HOIST INSPECTIONS

---

The inspection procedure for manually lever operated hoists in regular service is divided into two general classifications as outlined in ASME B30.21. These two general classifications are based upon the intervals at which inspections should be performed. The intervals are also dependent upon the nature of the critical components of the equipment, and the degree of exposure of equipment components and parts to wear and deterioration. The degree of exposure is dependent upon hoist activity, severity of hoist service, and the environment of hoist location. These two general classifications of inspection are designated as frequent and periodic.

**FREQUENT INSPECTION:** Frequent inspections are visual and audio external inspections and examinations by the operator or other designated personnel with no records required. Usual or minimum inspection intervals are as follows:

|                       |                     |
|-----------------------|---------------------|
| <b>Normal service</b> | — monthly           |
| <b>Heavy service</b>  | — weekly to monthly |
| <b>Severe service</b> | — daily to weekly   |

**PERIODIC INSPECTION:** Periodic inspections are visual, hands-on, and audio external inspections and examinations by designated personnel making written records of external conditions to provide the bases for a continuing evaluation of the hoist and components. If the external inspection indicates the need, disassembly may be required to make a more detailed inspection and examination. Usual or minimum inspection intervals are as follows:

|                       |                |
|-----------------------|----------------|
| <b>Normal service</b> | — annually     |
| <b>Heavy service</b>  | — semiannually |
| <b>Severe service</b> | — quarterly    |

### **WARNING**

THE INSPECTION INTERVALS LISTED ABOVE ARE THE USUAL OR MINIMUM RECOMMENDATIONS AND ARE FOR REFERENCE PURPOSES ONLY. THEY ARE BASED ON SINGLE SHIFT OPERATION UNDER NORMAL OPERATING CONDITIONS AND NORMAL ENVIRONMENTAL CONDITIONS. ACTUAL OPERATING AND ENVIRONMENTAL CONDITIONS SHOULD BE REVIEWED BY A QUALIFIED PERSON AND APPROPRIATE INSPECTION INTERVALS ESTABLISHED ON THE RECOMMENDATIONS OF THE QUALIFIED PERSON.

## FREQUENT AND PERIODIC HOIST INSPECTIONS

---

Definitions of service taken from ASME B30.21 for manually lever operated hoists.

**Normal service** involves operation of the equipment with randomly distributed loads within the rated load limit, or uniform loads less than 65% of rated load, for not more than 15% of the time of a single work shift for manually-operated equipment and not more than 25% of the time of a single work shift for electric-powered equipment.

**Heavy service** involves operation of the equipment within the rated load limit that exceeds normal service.

**Severe service** involves operation of the equipment in normal service or heavy service with abnormal operating conditions.

The ASME standards state: A manually lever operated hoist that is not in regular service, that has been idle for a period of one month or more, but less than one year, shall be inspected in accordance with the requirements for frequent inspection before being placed into or back into service.

The ASME standards state: A manually lever operated hoist that is not in regular service, that has been idle for a period of one year or more, shall be inspected in accordance with the requirements for periodic inspection before being placed into or back into service.

Recommended items to be checked for deficiencies or damage during *frequent* and *periodic* inspections are outlined in Table 2, pages 21 to 24 for manually lever operated hoists. Also, refer to the manual furnished by the manufacturer of the hoist for additional information on frequent and periodic inspections.

Detailed inspection procedures for some items should be found in specific sections of the manual furnished by the manufacturer with the equipment. Inspections may be performed with the hoist in its normal location and do not require that the hoist be disassembled. Covers and other items normally supplied to allow inspection of components should be opened or removed for these inspections. Any deficiencies or damage such as those listed in Table 2, page 21 shall be examined by a designated person to determine whether they constitute a hazard, or whether any disassembly is necessary for a more detailed inspection. The hoist operator should make observations during regular operation for any deficiencies or damage that might appear between inspections.

## FREQUENT AND PERIODIC HOIST INSPECTIONS

---

|   |
|---|
| <p><b>TABLE 2</b><br/> <b>MANUALLY LEVER OPERATED HOISTS</b><br/> <b>FREQUENT AND PERIODIC INSPECTIONS</b><br/> <b>(REFER ALSO TO THE MANUAL FURNISHED BY THE HOIST MANUFACTURER)</b></p> |
|---|

| INSPECTION<br>ITEM                                    | <u>INSPECTION</u> |          | DESCRIPTION OF INSPECTION<br>CHECK POINTS   |
|---|-------------------|----------|---|
|   | FREQUENT          | PERIODIC |   |
| All Functional Mechanisms                             | •                 | •        | Check for proper operation and adjustment.  |
| Controls  | •                 | •        | Check that all direction motions agree with directional selection setting when lever is actuated.   |
| Hooks   | •                 | •        | Check for damage, cracks, nicks, gouges, deformation of the throat opening, bending of the shank on neck, wear on the saddle or load bearing point, and twist.  |
| Hook Latches  | •                 | •        | Check that hook latches, if provided, are not missing and that they operate properly.   |
| Operating Lever                                       | •                 | •        | Check for bends, cracks, and other damage.  |
| Tensioning Medium – Load Chain (Welded Link & Roller) | •                 | •        | Check while under load in lifting and lowering direction – observe chain and sprockets. Chain should feed smoothly in both directions. If chain jumps, binds, or is noisy, clean and lubricate. If problem persists, inspect chain and mating parts for wear, distortion, and damage per manufacturer’s manual. |

## FREQUENT AND PERIODIC HOIST INSPECTIONS

---

|   |
|---|
| <p><b>TABLE 2</b><br/> <b>MANUALLY LEVER OPERATED HOISTS</b><br/> <b>FREQUENT AND PERIODIC INSPECTIONS (CONTINUED)</b><br/> <b>(REFER ALSO TO THE MANUAL FURNISHED BY THE HOIST MANUFACTURER)</b></p> |
|---|

| INSPECTION<br>ITEM      | INSPECTION |          | DESCRIPTION OF INSPECTION<br>CHECK POINTS   |
|-------------------------|------------|----------|---|
|                         | FREQUENT   | PERIODIC |   |
| Wire Rope               | •          | •        | Check for distortion, kinking, crushing, unstranding, birdcaging, main strand displacement, and core protrusion; general corrosion; broken and cut strands; number, distributions and type of visible broken wires (12 randomly distributed broken wires in one lay or four broken wires in one strand and one outer wire broken at the contact point with the core which has worked its way out and protrudes or loops out is cause for removal from service). |
| Web Strap               | •          | •        | Check for gross damage from melting and charring; acid or caustic burns; weld spatter; broken stitching; cuts or tears; damaged eyes or fittings; abrasive wear; and knots.   |
| Reeving                 | •          | •        | Check that tensioning medium is properly reeved and that it is not kinked or twisted, and that parts are not twisted about each other.  |
| Brakes<br>(if equipped) | •          | •        | Check that hoist motion does not have excessive drift and that stopping distance is normal.   |



## FREQUENT AND PERIODIC HOIST INSPECTIONS

**TABLE 2**  
**MANUALLY LEVER OPERATED HOISTS**  
**FREQUENT AND PERIODIC INSPECTIONS (CONTINUED)**  
**(REFER ALSO TO THE MANUAL FURNISHED BY THE HOIST MANUFACTURER)**

| INSPECTION<br>ITEM   | <u>INSPECTION</u> |          | DESCRIPTION OF INSPECTION<br>CHECK POINTS  |
|--|-------------------|----------|--|
|  | FREQUENT          | PERIODIC |  |
| Ratchet and Pawl<br>(if equipped)                            | •                 | •        | Check for proper operation of springs and pawls. Make sure pawls operate freely and that load is controlled during operation.    |
| Oil or Grease Leakage  | •                 | •        | Check for any sign of oil or grease leakage on the hoist.  |
| Unusual Sounds   | •                 | •        | Check for any unusual sounds from the hoist and hoist mechanism while operating the hoist.                                       |
| Warning and Safety<br>Labels                                 | •                 | •        | Check that warning and other safety labels are not missing and that they are legible.  |
| Hoist Frame and<br>Support                                   | •                 | •        | Check for damage that would effect strength such as gouges, cracks, bending, and distortion.                                     |
| Fastening Devices<br>(bolts, nuts, pins, etc.)               |                   | •        | Check for items not properly secured (tightened), damaged, or missing (torque bolts per hoist manufacturer's recommended values) |
| Load Sprockets, Idler<br>Sprockets, Guides, and<br>Strippers |                   | •        | Check for cracks, damage to grooves, and excessive wear.   |

## FREQUENT AND PERIODIC HOIST INSPECTIONS

**TABLE 2**  
**MANUALLY LEVER OPERATED HOISTS**  
**FREQUENT AND PERIODIC INSPECTIONS (CONTINUED)**  
**(REFER ALSO TO THE MANUAL FURNISHED BY THE HOIST MANUFACTURER)**

| INSPECTION<br>ITEM  | INSPECTION<br>FREQUENT PERIODIC | DESCRIPTION OF INSPECTION<br>CHECK POINTS  |
|---|---------------------------------|--|
| Load block,<br>Suspension, and Frame  | •                               | Check for cracks, damage, and distortion.  |
| Tensioning Medium<br>Attachments, Clevises,<br>Yokes, Suspension Bolts,<br>Shafts, Gears, Bearings,<br>Pins, Rollers, and Locking<br>and Clamping Devices | •                               | Check for wear, corrosion, damage, and distortion.   |
| Hook Retaining Devices  | •                               | Check for damage to hook retaining nuts, collars, pins, welds, rivets, etc. used to secure hooks.                                      |
| Brake Mechanism<br>(if equipped)  | •                               | Check for worn, glazed, or oil-contaminated friction discs; worn pawls, cams, or ratchet; corroded, stretched, or broken pawl springs. |
| Ratchet and Pawl<br>(if equipped)   | •                               | Check for worn and corroded pawls, cams, and ratchets; corroded, stretched and broken pawl springs.                                    |
| Tensioning Medium<br>End Connection<br>Overtravel Restraint   | •                               | Check for looseness, cracks, damage, and distortion.   |
| Capacity Warning and<br>Safety Labels   | •                               | Check that capacity, warning, and other safety labels are not missing and that they are legible.                                       |
| Load Limiting Devices<br>(if equipped)  | •                               | Check per manufacturer's manual.   |

## FREQUENT AND PERIODIC HOIST INSPECTIONS

---

### **⚠ WARNING**

IF ANY DAMAGE OR MALFUNCTIONS ARE NOTED BY THE FREQUENT OR PERIODIC INSPECTION ITEMS OF TABLE 2, THE HOIST SHALL BE TAGGED WITH AN OUT-OF-ORDER SIGN AND SHALL NOT BE RETURNED TO REGULAR OPERATION UNTIL MAINTENANCE AND REPAIR OF THE DAMAGE OR DEFICIENCIES FOUND DURING THE INSPECTION HAVE BEEN CORRECTED.

Records of the condition of critical components such as wire rope, load chain, hooks, and brakes observed during frequent and periodic inspections should be established. This record should also record replacement, maintenance, and repair information. Use of this recorded information should be a basis for the establishment of a preventative maintenance program for replacement of wearing components on a regular basis, thereby eliminating or reducing unscheduled downtime situations.

## HOIST INSPECTION REPORTS

---

Written reports are not required by the ASME B30.21 volume for daily inspections or frequent inspections. Some companies use a daily inspection report form to serve as a notice that the equipment needs or may soon need service. It is a means to convey such information to the maintenance department that repairs are or may be required and that the equipment may be required to be taken out of service. Some companies have also established procedures requiring a written inspection report for frequent inspections.

Written reports, however, are required by the ASME B30.21 volume for periodic inspections. Note that an acceptable alternative to written reports is an external coded mark on the hoist. (If a metal stamp is used, it shall not be placed in a highly stressed area). This can be accomplished by the use of pre-printed forms for use by the inspector. The inspection forms can be prepared specifically for use to meet the needs of an individual company. Some software programs are available with forms established. A listing of inspection report forms is presented below with sample forms shown in Appendix C. These sample forms can be used as guides by companies that need to develop an inspection program.

## HOIST INSPECTION REPORTS

---

This particular form program uses one cover sheet for the inspection report form and six different inspection report forms, each covering a specific type of equipment or component, as follows:

### APPENDIX AND FORM NO.

### EQUIPMENT COVERED

---

|    |  |
|----|--|
| L1 | Inspection Report Form (1 sheet) (this is a cover sheet for the inspection report) |
| L2 | Manually Lever Operated Hoist Inspection Report Form (2 sheets)                    |
| L3 | Wire Rope Inspection Report Form (2 sheets)  |
| L4 | Load Chain Inspection Report Form (1 sheet)  |
| L5 | Hook Inspection Report Form (1 sheet)  |
| L6 | Web Strap Inspection Report Form (1 sheet)   |

An inspection report sheet should always be used along with the applicable form or forms for the equipment being inspected. The report sheet shows by check marks the form or forms used and attached. The report sheet also shows by check mark the action determined as a result of the inspection to be required.

## HOOK INSPECTION

Load hooks on hoists in regular service should be visually inspected daily by the operator. If the hoist is used in multiple-shift operations, load hooks should be visually inspected by the operator at the start of each shift. When visual inspection indicates that a more detailed inspection is required, the following are some recommended inspection procedures in addition to what is stated in the manual furnished by the manufacturer with the hoist. These procedures also would apply to scheduled frequent and periodic inspections.

1. Measure hook throat opening from metal to metal of the hook as shown by dimension E in Figure 2 below. DO NOT measure from latch to metal unless indicated in manufacturer's manual. Hook must be replaced when throat opening measurement has increased 15% over the original throat opening dimension of a new hook. The manual furnished with some hoists will include original dimensions and replacement dimensions for throat openings of standard hooks specified for the hoist line. Some hook manufacturers provide gauge marks on hooks. To aid in measuring the throat opening, it is recommended the hoist owner/user make a gauge of the dimensions shown in the manual. This will allow quick measurement of the throat opening and immediate indication when hook replacement is required.

If hook throat opening dimensions are not covered in the manual furnished with the hoist, the hook throat opening should be measured by the owner/user prior to installing the hoist. This will establish a reference point to use in future inspections for determination when the throat opening dimension has increased 15% requiring hook replacement. A gauge similar to the one discussed above is recommended. The gauge should have the throat opening dimension measured prior to installation, and a dimension 15% greater than the throat opening dimension measured prior to installation.

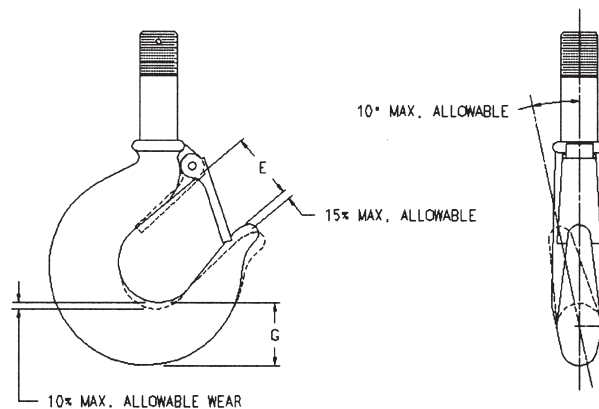

FIGURE 2

## HOOK INSPECTION

---

2. Measure the hook depth at load bearing point (base, bowl, or saddle) of the hook as shown by dimension G in Figure 2 above. Hook must be replaced when wear at load bearing point is 10% of the original depth of the hook load bearing point. The manual furnished by the manufacturer with the hoist may include original dimensions and replacement dimensions for depth at load bearing point of standard hooks specified for the hoist line.

If hook depth at load bearing point dimensions are not covered in the manual furnished with the hoist, the hook depth at load bearing point should be measured by the owner/user prior to installing the hoist. This will establish a reference point to use in future inspections for determination when wear at the load bearing point has reached 10% requiring hook replacement.

3. A bend or twist of the hook exceeding 10° from the plane of the unbent hook requires replacement of the hook. Refer to Figure 2, page 27.
4. A hook latch, when required on the hoist, that is missing shall be replaced.
5. A hook latch, when required on the hoist, that is inoperative shall be repaired or replaced.
6. A hook with a hook latch that does not close the throat opening of the hook, and the hook opening does not exceed the requirements of item 1 on page 27, shall be removed from service or moused until the latch is replaced or repaired.
7. Hooks having damage from chemicals, corrosion, or deformation shall be repaired or replaced. Damage in the form of cracks, nicks, and gouges may be repaired by a designated person by grinding longitudinally, following the contour of the hook, provided no dimension of the hook is reduced by more than 10% of the original dimension of a new hook. If the repair reduces the dimension of the hook by more than 10% of the original dimension of a new hook, the hook shall be replaced.

### **NOTICE**

A HOOK THAT REQUIRES REPLACEMENT BECAUSE OF EXCESSIVE BENDS, TWISTS, OR THROAT OPENING INDICATES ABUSE OR OVERLOADING OF THAT MANUALLY LEVER OPERATED HOIST. THEREFORE, OTHER LOAD SUPPORTING COMPONENTS OF THAT HOIST SHOULD BE INSPECTED FOR POSSIBLE DAMAGE WHEN SUCH CONDITIONS ARE FOUND.

## HOOK INSPECTION

---

### **⚠ CAUTION**

NEVER REPAIR HOOKS BY WELDING OR RESHAPING. HEAT APPLIED TO THE HOOK WILL ALTER THE ORIGINAL HEAT TREATMENT OF THE HOOK MATERIAL AND CHANGE THE STRENGTH OF THE HOOK.

NEVER WELD HANDLES OR OTHER ATTACHMENTS TO THE HOOK. HEAT APPLIED TO THE HOOK WILL ALTER THE ORIGINAL HEAT TREATMENT OF THE HOOK MATERIAL AND CHANGE THE STRENGTH OF THE HOOK. IF HANDLES OR OTHER ATTACHMENTS ARE REQUIRED ON THE HOOK, CONTACT THE MANUFACTURER OF THE HOIST.

## WIRE ROPE INSPECTION

Wire rope on hoists in regular service should be visually inspected daily by the operator. If the hoist is used in multiple-shift operations, wire rope should be visually inspected by the operator at the start of each shift. The daily inspection by the operator is for visual damage to the wire rope. Such damage includes excessive broken wires and wear, broken strands, kinks, birdcaging, or damage resulting in deformation of the wire rope structure. When visual damage is present, the operator shall report such damage to the supervisor, and shall not operate the hoist until a more detailed inspection is performed to determine that the wire rope can be used, or the wire rope is replaced. Detailed inspection procedures are outlined below. These procedures also apply to scheduled frequent and periodic inspections.

### **⚠ WARNING**

**DO NOT OPERATE A MANUALLY LEVER OPERATED HOIST WITH WIRE ROPE THAT SHOWS ANY SIGN OF DAMAGE, DEFORMATION, OR EXCESSIVE WEAR.**

Wire rope consists of a core, strands, and wires that comprise a strand as shown in Figure 3 below. The diameter of the wire rope is the diameter of a circle that would enclose the wire-rope strands. Correct and incorrect methods of measuring wire-rope diameter are shown in Figure 4 below. The term one rope lay refers to the length of wire rope assembly wherein one strand completely wraps 360° around the wire-rope assembly.

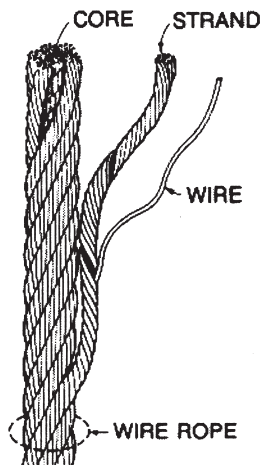

Figure 3

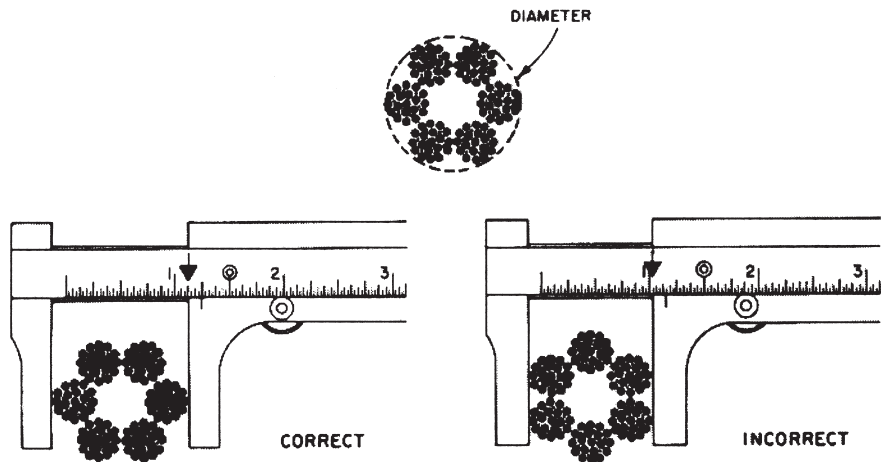

Figure 4



## WIRE ROPE INSPECTION

---

### **⚠ CAUTION**

ALWAYS WEAR GLOVES OR OTHER HAND PROTECTION DEVICES WHEN HANDLING WIRE ROPE.

Wire rope items to be included for inspection during scheduled frequent and periodic inspections; or if the daily visual inspection by the operator indicates a more detailed inspection is required; are as follows:

1. Rope distortion such as kinking, crushing, unstranding, birdcaging, main strand displacement, or core protrusion.
2. General corrosion.
3. Broken or cut strands.
4. Number, distribution, and type of visible broken or cut wires.
5. Reduction of rope diameter due to loss of core support, internal or external corrosion, or wear of outer wires.
6. Damage from heat.
7. Corroded or broken wires at end connections.
8. Corroded, cracked, bent, worn, damaged, or improperly applied end connections.
9. Wire rope pull through of end connection.
10. Tightening of clamping-type end connections. Checking torque of bolts of end connections for clamps that recommend a specified torque on the clamp bolts.
11. Rope lubrication, if recommended.

## **WIRE ROPE INSPECTION**

---

During wire rope inspection, special attention should be directed to sections of rope subject to rapid deterioration such as the following:

- Rope sections in contact with saddles, equalizer sheaves, or other sheaves where rope travel is limited.
- Rope sections at or near terminal ends where corroded or broken wires may protrude.
- Rope sections subject to reverse bends.
- Rope sections that are normally hidden during visual inspections, such as sections passing over sheaves.

Rope conditions found during the inspection should be recorded in a written report. Amount and type of rope deterioration from one inspection report until the next inspection report should be evaluated for determination if rope replacement is required.

## WIRE ROPE INSPECTION

---

### WIRE ROPE REPLACEMENT

Rope conditions found during an inspection, in addition to review of previous inspection reports, should be the basis for determination as to whether that hoist use should be discontinued and rope replacement is required. Rope conditions requiring replacement of the rope include the following:

1. One broken strand.
2. Twelve randomly distributed broken wires in one rope lay.
3. Four broken wires in one strand in one rope lay.
4. One outer wire broken at the contact point with the core of the rope that has worked its way out of the rope structure and protrudes or loops out from the rope structure.
5. Wear of one-third of the original diameter of outside individual wires.
6. Kinking, crushing, unstranding, birdcaging, main strand displacement, core protrusion, or any other damage resulting in deformation or distortion of the rope structure.
7. Evidence of heat damage from any cause.
8. Corroded or two broken wires at a socketed or swaged end fitting.
9. Corroded, cracked, bent, damaged, or worn end fitting.
10. Reduction of rope nominal diameter greater than
  - 1/64 inch (0.4 mm) for rope diameters up to and including 5/16 inch (8 mm).
  - 1/32 inch (0.8 mm) for rope diameters over 5/16 inch up to and including 1/2 inch (13 mm).

## **WIRE ROPE INSPECTION**

---

### **WIRE ROPE MAINTENANCE**

Only authorized replacement wire rope assemblies, with wire rope constructions and end fittings in accordance with design specifications established by the hoist manufacturer, should be used when replacing wire rope on the hoist.

Specific attention should be directed to the following:

- Wire rope should be stored in a manner to prevent damage or deterioration to the rope.
- Wire rope should be unreeled or uncoiled in a manner to avoid kinking of or inducing a twist in the rope.
- During installation of wire rope, care should be exercised to avoid dragging the rope in dirt or around objects that will scrape, nick, cut, crush, or induce sharp bends in the rope.
- If recommended, rope should be maintained in a lubricated condition.

The load block on new hoists or after installation of replacement rope may turn when a load is applied or released. Such load block turning may cause the lines of rope to twist about each other. Do not operate the hoist in this condition. This indicates a twist was induced into the rope during installation. Remove the rope from the hoist, lay the rope out to remove any twist, and re-install on the hoist. For additional information on removing a twist in the wire rope, refer to the manual furnished with the hoist or contact the hoist manufacturer.

When replacing wire rope, inspect the drum and sheaves. Drums that have scored grooves or have sharp edges from wear should be smoothed out or the drum should be replaced. Sheaves that have scored grooves, cracked or broken flanges, or sharp edges from wear should be replaced.

### **TO REPLACE WIRE ROPE**

Wire rope should be replaced in accordance with the instructions outlined in the manual furnished by the manufacturer with the hoist. The original reeving arrangement of the hoist must be followed when replacing wire rope.

## WIRE ROPE INSPECTION

---

### **⚠ CAUTION**

WHEN GUIDING THE WIRE ROPE INTO THE DRUM GROOVES, USE ONLY A LIGHT SQUEEZING PRESSURE. DO NOT SQUEEZE ROPE THAT WILL PERMIT HAND BEING PULLED INTO THE GROOVES AND ROPE. KEEP HANDS WELL POSITIONED AWAY FROM DRUM. ALWAYS WEAR GLOVES OR OTHER HAND PROTECTION DEVICES WHEN HANDLING WIRE ROPE. NEVER HANDLE MOVING WIRE ROPE WITH BARE HANDS.

## LOAD CHAIN INSPECTION

---

Load chain on hoists in regular service should be visually inspected daily by the operator. If the hoist is used in multiple-shift operations, load chain should be visually inspected by the operator at the start of each shift. The daily inspection by the operator is for visual damage to the load chain. Such damage includes wear, gouges, nicks, weld spatter, corrosion, and distorted links. The load chain should feed smoothly into and away from chain sprockets when the hoist is operated. When visual damage is present, the operator shall report such damage to the supervisor, and shall not operate the hoist until a more detailed inspection is performed to determine that the load chain can be used, or the load chain has to be replaced. The following are some recommended inspection procedures in addition to what is stated in the manual furnished by the manufacturer with the hoist. These procedures also would apply to scheduled frequent and periodic inspections.

### **⚠ WARNING**

DO NOT OPERATE A MANUALLY LEVER OPERATED HOIST WITH LOAD CHAIN THAT SHOWS ANY SIGN OF DAMAGE, DEFORMATION, OR EXCESSIVE WEAR.

## LOAD CHAIN INSPECTION

### WELDED LINK LOAD CHAIN

Load chain items recommended for inspection, and conditions which may require replacement, during scheduled frequent and periodic inspections, or if the daily visual inspection by the operator indicates a more detailed inspection is required, are as follows:

1. Clean chain before inspection to permit full inspection of the load chain.
2. Attach a load to the hoist and operate hoist in the lifting and lower directions. Observe operation of load chain and chain sprockets. The chain should feed smoothly into and away from chain sprockets. If the load chain binds, jumps, or is noisy, inspect the chain and mating parts for wear, distortion, or other damage.

## LOAD CHAIN INSPECTION

---

3. Attach a light load (approximately 50 to 100 pounds) on the hook and check load chain for wear and elongation. Chain wear and elongation are checked by measuring a specified length (specified number of chain links called gauge length) of chain. Gauge length is shown in Figure 5 below. Figure 5 shows two gauge length figures because hoist manufacturers may denote gauge length in two different ways. Refer to manufacturer's manual for information.

The chain gauge length for a new length of load chain, and the measured gauge length when load chain should be replaced is normally outlined in the manual furnished with the hoist. If such information is not available, proceed as follows:

- a. Select an unworn and unstretched length of chain (e.g., at the slack end of the chain). The number of links selected must be an odd number and should be approximately 12 inches to 24 inches in length.

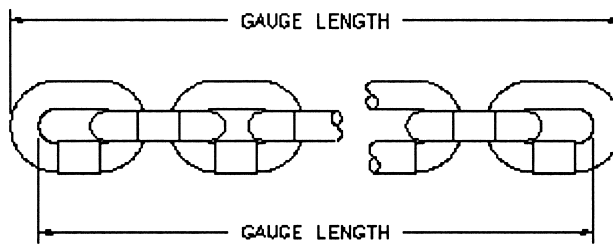

FIGURE 5

- b. Measure the gauge length of the unworn and unstretched length of chain selected by use of a caliper-type gauge.
  - c. Measure the gauge length of the same number of links in a used section of the load chain.
  - d. Replace the load chain if the used gauge length is  $2\frac{1}{2}\%$  longer than the unused gauge length for manually operated hoists.
4. Conduct a link by link inspection for gouges, nicks, weld spatter, corrosion, and distorted links. The existence of any of these types of damage shall be reason to replace load chain.

## LOAD CHAIN INSPECTION

---

5. Slacken the load chain and move adjacent links to one side and inspect each link for inter-link wear at the link contact points. If inter-link wear is observed, measure the thickness of the link at the contact point. If wear is greater than 10% of the original wire diameter of the chain, for manually lever operated hoists, the load chain shall be replaced.

### **⚠ CAUTION**

NEVER REPAIR LOAD CHAIN BY WELDING OR RESHAPING. HEAT APPLIED TO THE LOAD CHAIN WILL ALTER THE ORIGINAL HEAT TREATMENT OF THE CHAIN MATERIAL AND CHANGE THE STRENGTH OF THE CHAIN, AND WILL DISTORT THE CHAIN LINKS RESULTING IN LINKS NOT FITTING POCKETS OF CHAIN SPROCKET.

## ROLLER LOAD CHAIN

Roller load chain inspection criteria for frequent and periodic inspections are provided as follows. These criteria should also be used if the daily visual inspection by the operator indicates that a more detailed inspection is required.

1. Attach a load to the hoist and operate hoist in the lifting and lowering directions. Observe operation of the load chain and chain sprockets. The chain should feed smoothly into and away from chain sprockets. If load chain binds, jumps, or is noisy, inspect chain and mating parts for wear, distortion, and other damage.

Note that chain must be clean and properly lubricated to perform properly without binding and noise. Clean and lubricate per manufacturers recommendations if necessary.

2. Attach a light load (approximately 50 to 100 lbs.) on the hook and check roller load chain for excess wear and elongation. Refer to manufacturers recommendations. In the absence of specific instructions the chain can be checked by determining the pitch in an unused section, measuring a 12 inch section (near the free end), and comparing it to a section that normally travels over the load sprocket. Using a caliper, measure the dimension from the edge of one chain pin to the corresponding edge of another pin for the number of pitches per foot. If elongation exceeds 1/4 in. in 12 inches, the chain should be replaced. As an example, a 3/4 in. pitch chain would contain 16 pitches in a 12 in. section. Chain should be replaced if the measurement over 16 pitches exceeds 12 1/4 inches.



## LOAD CHAIN INSPECTION

---

3. Check the chain while hanging with the 50 to 100 lb. load for twist. Replace chain if twist in any 5 ft. section exceeds 15°.
4. Check the chain while hanging with the 50 to 100 lb. load for straightness. Replace chain if bow exceeds 1/4 in. in any 5 ft. section.
5. Inspect clean chain for the following. Replace chain if following conditions are observed:
  - Pins turned from original position.
  - If chain has rollers, rollers that do not turn freely. (Some chains do not have rollers).
  - Joints that do not easily flex (hand effort).
  - Side plates spread open. Visually compare pin head extension with pin head extension of chain at free end to determine amount of spread.
  - Corrosion, pitting, and discoloration. These are signs of serious impairment.
  - Gouges, nicks, and weld spatter.

## LOAD CHAIN REPLACEMENT

Only authorized replacement load chain, with design specifications established by the hoist manufacturer, should be used when replacing load chain on the hoist. Load chain is specifically designed for a particular hoist. Load chain from one manufacturer should not be used on a hoist manufactured by a different manufacturer.

When replacing load chain, inspect the chain sprockets and all mating parts such as chain guides and chain strippers. Sprockets that have scored pockets, cracked or broken flanges, excessive pocket wear, or sharp edges from wear should be replaced. Guides and strippers that are worn or damaged should be replaced.

### **WARNING**

**DO NOT REPAIR LOAD CHAIN BY WELDING OR HEATING.**

Load chain should be replaced in accordance with the instructions outlined in the manual furnished by the manufacturer with the hoist. The original reeving arrangement of the hoist must be followed when replacing load chain.

Load chain links that pass over the hoist drive load sprocket on edge (alternate to those links that lie flat in the sprocket pockets) shall be installed (unless otherwise recommended by the hoist manufacturer) with the welds away from the center of the drive sprocket.

Load chain shall be installed without any twist between the hoist and load block or between hoist or load block and an anchored end connection on either the loaded side or the slack side of the load chain.

Load chain should be maintained in a lubricated condition.

## **WEB STRAP INSPECTION**

---

Web strap inspection criteria for scheduled frequent and periodic inspections are provided as follows. These criteria should also be used if the daily visual inspection by the operator indicates that a more detailed inspection is required.

1. Remove the web strap from the drum to permit examination of its entire length.
2. Examine visually for obvious gross damage such as melting or charring, acid or caustic burns, weld spatter, broken stitching, cuts or tears, damaged eyes or fittings, abrasive wear, knots and narrowing due to overloading.
3. Examine visually for rapid deterioration at web strap sections in contact with saddles, equalizer sheaves, and other sheaves where strap travel is limited; at sections of web strap near terminal ends where broken threads or cuts may be evident; at web strap sections subject to reverse bends; and at web strap sections that are normally hidden during visual inspections such as parts passing over sheaves.

### **WEB STRAP REPLACEMENT**

Only authorized web strap with design specifications established by the hoist manufacturer should be used when replacing web strap on the manually lever operated hoist. Web strap from one manufacturer should not be used on a hoist manufactured by another manufacturer.

When replacing the web strap make certain that mating hardware items are thoroughly inspected for excessive wear, corrosion, damage, and distortion.

Web strap shall be installed without twists between the hoist and load block or anchored ends.

## **LOAD CONTROLLING MECHANISM – HOIST BRAKING SYSTEM/RATCHET AND PAWL OPERATION**

The load controlling mechanism of manually lever operated hoists perform the following functions under normal operating conditions and with test loads up to 125% of rated load.

- Stop and hold the load when the lever force is removed and the lever stroke has been completed.
- Provide for incremental movement of the load when lifting or lowering.

The hoist braking system / ratchet and pawl operation on hoists in regular service should be checked without load on the hook by the operator at the start of each shift, or the first time the hoist is to be operated during each shift. The hoist braking system should be checked during scheduled frequent and periodic inspections.

Every hoist manufacturer has a braking system / ratchet and pawl design that is unique in the manner in which it operates and performs. Therefore, general guidelines for testing and adjusting all hoists cannot be outlined. Refer to the manual furnished by the manufacturer with the hoist for testing procedures, inspection, adjustment, and replacement of components of the braking system / ratchet and pawl operation.

## **HOIST TESTING**

### **OPERATIONAL TEST**

As mandated in B30.21, all altered or repaired hoists, or hoists that have not been used for the past 12 months, shall be tested before being placed in service by or under the direction of a designated person.

All functions of the hoist shall be checked with the hoist suspended in the unloaded state. Some hoists may require a small load or pull on the load hook to test the lowering motion.

After testing in the unloaded state, a load of at least 100 lbs. (46 kg.) times the number of load supporting parts of tensioning medium shall be applied to the hoist in order to check for proper load control (brake operation or ratchet and pawl operation).

### **LOADTEST**

As mandated in B30.21, all hoists in which load sustaining parts have been altered, replaced, or repaired shall be tested statically or dynamically by or under the direction of an appointed person and a record of such test shall be made.

The applied test load shall be at least equal to the rated load, or greater, as recommended by the hoist manufacturer (refer to hoist manual). Note that the replacement of the tensioning medium (only) is specifically excluded from this load test requirement. However, all functions of the hoist must be checked (refer to Operational Test section) prior to putting the hoist back in service.

Note also that test anchorages or suspensions must be approved by a qualified person.

## APPENDIX A

---

### DEFINITIONS OF VARIOUS HOIST TERMS

**abnormal operating conditions:** environmental conditions that are unfavorable, harmful, or detrimental to or for the operation of a hoist, such as excessively high or low ambient temperatures, exposure to weather, corrosive fumes, dust laden or moisture laden atmospheres, and hazardous locations.

**appointed:** assigned specific responsibilities by the employer or the employer's representative.

**block, load:** the assembly of hook or shackle, swivel, bearings, sheaves, sprockets, pins, and frame suspended by the load chain, wire rope, or web strap. This shall include any appurtenances reeved in the load chain, wire rope, or web strap.

**brake:** a device for retarding and stopping motion of the load (see **load controlling mechanism**).

**chain, load:** the load-bearing chain in a hoist.

**chain, roller:** a series or alternately assembled roller links and pin links in which the pins articulate inside the bushings and the rollers are free to turn on the bushings. Pins and bushings are press fit in their respective link plates.

**chain, rollerless:** a series of alternately assembled roller links and pin links in which the pins articulate inside the bushings with rollers on the bushing omitted. Pins and bushings are press fit in their respective link plates.

**chain, welded link:** a chain consisting of a series of interwoven links formed and welded.

**designated person:** a person selected or assigned by the employer or the employer's representative as being competent to perform specific duties.

**drum:** the cylindrical member around which the wire rope or web strap is wound for lifting and lowering the load.

**friction brake:** see load controlling mechanism

**guide, chain:** a means to guide the load chain at the load sprocket.

**guide, web strap:** a means to guide the web strap at the load sprocket (drum).

## APPENDIX A

---

### DEFINITIONS OF VARIOUS HOIST TERMS

**guide, wire rope:** a means to guide the wire rope at the load sprocket (drum).

**hoist, lever operated:** a lever operated manual device used to lift, lower, or pull a load and to apply or release tension.

**hook latch:** a mechanical device to bridge the throat opening of a hook, but not to support the load.

**load:** the total superimposed weight on the load block or hook.

**load, rated:** the maximum load for which a hoist is designated by the manufacturer.

**load controlling mechanism:** a mechanism that functions automatically to hold and control the load. In each of the following general types, a reciprocating force must be applied to the hoist lever to lower the load.

**friction brake type:** an automatic type of brake used for holding and controlling loads. This unidirectional device requires a force applied to the operating lever to lower the load, but does not impose additional lever pull when lifting the load.

**ratchet and pawl type:** a load controlling mechanism consisting of interlocking pawl(s) and ratchet that act to hold the load by mechanical engagement.

**load hook:** the hook used to connect the load to the hoist.

**normal operating conditions:** conditions during which a hoist is performing functions within the scope of the original design.

**operating lever:** the lever or handle provided to operate the hoist.

**overload:** any load greater than the rated load.

**overtravel restraint:** a device used to prevent the slack load chain from inadvertently being lowered past the load sprocket.

**parts (lines):** number of lines of chain, wire rope, or web strap supporting the load block or hook.

**pawl:** a device for holding the machinery against undesired rotation by engaging a ratchet.

## APPENDIX A

---

### DEFINITIONS OF VARIOUS HOIST TERMS

**qualified person:** a person who, by possession of a recognized degree in an applicable field, or certificate of professional standing, or who, by extensive knowledge, training, and experience, has successfully demonstrated the ability to solve or resolve problems relating to the subject matter and work.

**ratchet:** a toothed member for engagement with the pawl.

**reeving:** a system in which the chain, wire rope, or web strap travels around sprockets (drums) and sheaves.

**rope:** refers to wire rope unless otherwise specified.

**shall:** this word indicates that the rule is mandatory and must be followed.

**sheave:** a grooved wheel or pulley used with a rope or chain to change direction and point of application of a pulling force.

**should:** this word indicates that the rule is a recommendation, the advisability of which depends on the facts in each situation.

**sprocket, idler:** a freely rotating device that changes the direction of the load chain, wire rope, or web strap.

**sprocket, load:** a hoist component that transmits motion to the load chain, wire rope, or web strap. This component is sometimes called the **load wheel, load sheave, pocket wheel, chain wheel, or drum.**

**strap, web:** a fabric woven of high tenacity synthetic yarns.

**stripper:** a device that aids the load chain in leaving the load sprocket.



## APPENDIX B

---

### HOIST REFERENCE DOCUMENTS AND STANDARDS

HMI Recommended Practices – Manually Lever Operated Hoists

HMI Lever Operated Hoist Operators Manual

Publisher: Hoist Manufacturers Institute  
8720 Red Oak Blvd., Suite 201  
Charlotte, NC 28217

ASME HST-3-1999 Performance Standard for Manually Lever Operated Chain Hoists

ASME B30.9-1996 Safety Standard, Slings

ASME B20.10-1999 Safety Standard, Hooks

ASME B30.21-1999 Safety Standard, Manually Lever Operated Hoists

ASME B29.24M-1995 Roller Load Chains for Overhead Hoists

Publisher: The American Society of Mechanical Engineers  
Three Park Avenue  
New York, NY 10016

ASME Order Department  
22 Law Drive  
Box 2900  
Fairfield, NJ 07007-2900

**APPENDIX C**

---

**SAMPLE REPORT FORM**

**COMPANY** \_\_\_\_\_

**MANUALLY LEVER OPERATED HOIST INSPECTION REPORT (FORM L1)  
SHEET 1 OF 1**

Inspection Date: \_\_\_\_\_ Inspector: \_\_\_\_\_

Equipment Type: \_\_\_\_\_

Equipment Location and  
Number: \_\_\_\_\_

**HOIST**

Mfg \_\_\_\_\_

S/N \_\_\_\_\_

Cap \_\_\_\_\_

- ACTION:**
- Pass Inspection
  - OK to Use, Maintenance Required as Noted in Comments
  - Fail Inspection. Remove From Service Until Correction Action  
Required as Noted in Comments is Corrected.

**COMMENTS (Use Additional Sheets as Required):**

\_\_\_\_\_  
\_\_\_\_\_  
\_\_\_\_\_

- Forms Attached:**
- No. L2, Manually Lever Operated Hoist Inspection Form
  - No. L3, Wire Rope Inspection Form
  - No. L4A, Link Load Chain Inspection Form
  - No. L4B, Roller Load Chain Inspection Form
  - No. L5, Hook Inspection Form
  - No. L6, Web Strap Inspection Form

Signature and Date of Inspector: \_\_\_\_\_

Signature and Date of Supervisor: \_\_\_\_\_

## APPENDIX C

### SAMPLE REPORT FORM

COMPANY \_\_\_\_\_

#### MANUALLY LEVER OPERATED HOIST INSPECTION REPORT (FORM L2) SHEET 1 OF 3

Date: \_\_\_\_\_

S/N: \_\_\_\_\_

| ITEM NO. | DESCRIPTION OF DAMAGE TO LOOK FOR   | PASS | NEEDS ATTN. | COMMENTS |
|----------|---|------|-------------|----------|
| L2.1     | All Functional Operating Mechanisms:<br>Maladjustment that interferes with proper operation.<br>Unusual sounds. |      |             |          |
| L2.2     | Braking / Ratchet and Pawl Mechanism:<br>Slipping under load.<br>Difficult to release.                          |      |             |          |
| L2.3.1   | Brake Parts:<br>Brake Discs:<br>Glazing.<br>Oil contamination.  |      |             |          |
| L2.3.2   | Ratchet and Pawl:<br>Pawls and Pawl Springs:<br>Broken, Worn, Corroded, and Stretched                           |      |             |          |
| L2.4     | Tensioning Medium End Connections:<br>Looseness, Cracks, Damage, Distortion                                     |      |             |          |
| L2.5     | Tensioning Medium:<br>Refer to Inspection Report Form L3, L4, or L6 as appropriate                              |      |             |          |
| L2.6     | Reeving:<br>Kinks, twists, looping  |      |             |          |

# APPENDIX C

## SAMPLE REPORT FORM

COMPANY \_\_\_\_\_

**MANUALLY LEVER OPERATED HOIST INSPECTION REPORT (FORM L2)**  
**SHEET 2 OF 3**

Date: \_\_\_\_\_

S/N: \_\_\_\_\_

| ITEM NO.     | DESCRIPTION OF DAMAGE TO LOOK FOR  | PASS | NEEDS ATTN. | COMMENTS |
|--------------|--|------|-------------|----------|
| <b>L2.7</b>  | Hooks:<br>Refer to Hook Inspection Report Form L5  |      |             |          |
| <b>L2.8</b>  | Hook Retaining Devices:<br>Not tight or secure, damage to nuts, collars, pins, welds, rivets used to secure hooks. |      |             |          |
| <b>L2.9</b>  | Hook Latch:<br>Missing, damaged, does not close hook opening.  |      |             |          |
| <b>L2.10</b> | Hoist Frame:<br>Damage – gouges, distortion, cracks, bending.  |      |             |          |
| <b>L2.11</b> | Operating Lever:<br>Bends, cracks, broken, and distortion.   |      |             |          |
| <b>L2.12</b> | Gears:<br>Wear, broken teeth, cracks, lubrication.   |      |             |          |
| <b>L2.13</b> | Bearing and Shafts:<br>Wear, distortion, cracks, loose, lubrication.   |      |             |          |
| <b>L2.14</b> | Lubrication:<br>Lack of amount, dirty.   |      |             |          |
| <b>L2.15</b> | Load Block:<br>Cracks, distortion, loose bolts, pins, or nuts.   |      |             |          |

Signature and Date of Inspector: \_\_\_\_\_

Signature and Date of Supervisor: \_\_\_\_\_

**APPENDIX C**

---

**SAMPLE REPORT FORM**

**COMPANY** \_\_\_\_\_

**MANUALLY LEVER OPERATED HOIST INSPECTION REPORT (FORM L2)  
SHEET 3 OF 3**

Date: \_\_\_\_\_

S/N: \_\_\_\_\_

| <b>ITEM NO.</b> | <b>DESCRIPTION OF DAMAGE TO LOOK FOR</b>   | <b>PASS</b> | <b>NEEDS ATTN.</b> | <b>COMMENTS</b> |
|-----------------|--|-------------|--------------------|-----------------|
| <b>L2.16</b>    | Load Sprockets, Idlers, Guides, and Strippers:<br>Cracks, damage to grooves and wear |             |                    |                 |
| <b>L2.17</b>    | Supporting Structure:<br>Distortion, cracks.   |             |                    |                 |
| <b>L2.18</b>    | All Bolts, Pins, and Nuts:<br>Missing, damaged, distortion, loose.                   |             |                    |                 |
| <b>L2.19</b>    | Load Limiting Devices:<br>Proper operation per manufacturers specifications.         |             |                    |                 |
| <b>L2.20</b>    | WARNING, Instruction Labels, and Load Markings<br>Missing, illegible                 |             |                    |                 |

Signature and Date of Inspector: \_\_\_\_\_

Signature and Date of Supervisor: \_\_\_\_\_

# APPENDIX C

## SAMPLE REPORT FORM

COMPANY \_\_\_\_\_

**WIRE ROPE INSPECTION REPORT (FORM NO. L3)  
SHEET 1 OF 2**

Date: \_\_\_\_\_

S/N: \_\_\_\_\_

| ITEM NO.    | DESCRIPTION OF DAMAGE TO LOOK FOR  | PASS | NEEDS ATTN. | COMMENTS |
|-------------|--|------|-------------|----------|
| <b>L3.1</b> | Rope Distortion:<br>Kinking, crushing, unstranding, birdcaging, main strand displacement, or core protrusion. Replace if distortion exists.            |      |             |          |
| <b>L3.2</b> | Corrosion:<br>Replace if corrosion has caused broken wires.  |      |             |          |
| <b>L3.3</b> | Broken or Cut Strands:<br>Replace immediately if one strand is broken or cut.  |      |             |          |
| <b>L3.4</b> | Broken or Cut Wires:<br>Replace if twelve randomly distributed broken wires in one rope lay or four broken wires in one strand in one rope lay.        |      |             |          |
| <b>L3.5</b> | Reduction of Outside Diameter:<br>Loss of core support, wear of outer wires, stretch. Refer to equipment manual or ASME standard for replacement data. |      |             |          |
| <b>L3.6</b> | End Connection or Fitting:<br>Corroded, cracked, bent, damaged or worn. Loose or missing bolts or low bolt torque.                                     |      |             |          |

Signature and Date of Inspector: \_\_\_\_\_

Signature and Date of Supervisor: \_\_\_\_\_

**APPENDIX C**

---

**SAMPLE REPORT FORM**

**COMPANY** \_\_\_\_\_

**WIRE ROPE INSPECTION REPORT (FORM NO. L3)  
SHEET 2 OF 2**

Date: \_\_\_\_\_

S/N: \_\_\_\_\_

| <b>ITEM NO.</b> | <b>DESCRIPTION OF DAMAGE TO LOOK FOR</b>   | <b>PASS</b> | <b>NEEDS ATTN.</b> | <b>COMMENTS</b> |
|-----------------|--|-------------|--------------------|-----------------|
| <b>L3.7</b>     | Broken Wires at Socketed or Swaged End Fitting:<br>Replace if two broken wires at fitting. |             |                    |                 |
| <b>L3.8</b>     | Rope at End Fitting:<br>Rope pulling through fitting.                                      |             |                    |                 |
| <b>L3.9</b>     | Sheaves:<br>Damage to grooves, flanges, and bearings, wear, distortion and cracks.         |             |                    |                 |
| <b>L3.10</b>    | Drum:<br>Damage to grooves, wear, distortion, cracks.                                      |             |                    |                 |

Signature and Date of Inspector: \_\_\_\_\_

Signature and Date of Supervisor: \_\_\_\_\_

# APPENDIX C

## SAMPLE REPORT FORM

COMPANY \_\_\_\_\_

**LINK LOAD CHAIN INSPECTION REPORT (FORM NO. L4A)**  
**SHEET 1 OF 1**

Date: \_\_\_\_\_

S/N: \_\_\_\_\_

| ITEM NO. | DESCRIPTION OF DAMAGE TO LOOK FOR   | PASS | NEEDS ATTN. | COMMENTS   |
|----------|---|------|-------------|--|
| L4A.1    | Chain Condition:<br>Dirty, corroded   |      |             |  |
| L4A.2    | Chain Damage:<br>Gouges, nicks, weld spatter, corrosion, distorted links.                               |      |             |  |
| L4A.3    | Operation:<br>Binding, jumps, noisy.  |      |             |  |
| L4A.4    | Chain Wear and Elongation:<br>Refer to equipment manual or ASME standard for replacement data.          |      |             | Gage length over _____ links new<br>_____<br>Gage length over _____ links to replace _____<br>Gage length measured at time of inspection _____ |
| L4A.5    | Inter-Link Wear:<br>Refer to equipment manual or ASME standard for replacement data.                    |      |             | Wire diameter new _____<br>Wire diameter to replace _____<br>Wire diameter measured at time of inspection _____                                |
| L4A.6    | End Connection or Fitting:<br>Corroded, cracked, bent, damaged or worn. Loose or missing bolts or pins. |      |             |  |
| L4A.7    | Sprockets:<br>Damage, wear, distortion, cracks.   |      |             |  |

Signature and Date of Inspector: \_\_\_\_\_

Signature and Date of Supervisor: \_\_\_\_\_



## APPENDIX C

### SAMPLE REPORT FORM

COMPANY \_\_\_\_\_

#### ROLLER LOAD CHAIN INSPECTION REPORT (FORM NO. L4B) SHEET 1 OF 1

Date: \_\_\_\_\_

S/N: \_\_\_\_\_

| ITEM NO. | DESCRIPTION OF DAMAGE TO LOOK FOR   | PASS | NEEDS ATTN. | COMMENTS   |
|----------|---|------|-------------|--|
| L4B.1    | Roller Chain Condition:<br>Dirty, corroded, pitted, discolored.   |      |             |  |
| L4B.2    | Roller Chain Damage:<br>Gouges, nicks, weld spatter, pins turned from original position, rollers (if present) that do not turn freely, joints that do not flex, side plates spread open |      |             | Rollers should turn freely, joints should flex. Compare pin head extensions with unused section. |
| L4B.3    | Roller Operation:<br>Binding, jumps, noisy.   |      |             |  |
| L4B.4    | Roller Chain Wear and Elongation:<br>Refer to manufacturer's manual or compare pitch of worn section with unused section.   |      |             | Wear/elongation not to exceed 1/4 in. in 12 in.  |
| L4B.5    | Chain Twist:<br>Refer to manufacturer's manual or hang 50 to 100 lb. load and measure twist.  |      |             | Twist not to exceed 15° in 5 foot section.   |
| L4B.6    | Chain Straightness:<br>Refer to manufacturer's manual or hang 50 to 100 lb. load and measure straightness.  |      |             | Replace chain if bow exceeds 1/4 in. in 5 foot section.  |

Signature and Date of Inspector: \_\_\_\_\_

Signature and Date of Supervisor: \_\_\_\_\_

# APPENDIX C

## SAMPLE REPORT FORM

COMPANY \_\_\_\_\_

### HOOK INSPECTION REPORT (FORM NO. L5) SHEET 1 OF 1

Date: \_\_\_\_\_

S/N: \_\_\_\_\_

| ITEM NO.    | DESCRIPTION OF DAMAGE TO LOOK FOR  | PASS | NEEDS ATTN. | COMMENTS   |
|-------------|--|------|-------------|--|
| <b>L5.1</b> | Throat Opening:<br>Replace if opening exceeds 15% of new hook. Refer to equipment manual or ASME standard for replacement data.                |      |             | Throat opening new _____<br>Throat opening to replace _____<br><br>Throat opening measured at time of inspection _____ |
| <b>L5.2</b> | Hook Depth at Load Bearing Point:<br>Replace if wear exceeds 10% of new hook. Refer to equipment manual or ASME standard for replacement data. |      |             | Hook depth new _____<br>Hook depth to replace _____<br>Hook depth measured at time of inspection _____                 |
| <b>L5.3</b> | Twist:<br>Replace if bend or twist exceeds 10° from plane of unbent hook.  |      |             |  |
| <b>L5.4</b> | Hook Damage:<br>Gouges, nicks, weld spatter, corrosion, cracks, distortion.  |      |             |  |
| <b>L5.5</b> | Hook Latch:<br>Missing, not operative, does not close throat opening, damaged.   |      |             |  |
| <b>L5.6</b> | Retaining Members:<br>Damaged, loose.  |      |             |  |
| <b>L5.7</b> | Bearing:<br>Binding, lack of lube.   |      |             |  |

Signature and Date of Inspector: \_\_\_\_\_

Signature and Date of Supervisor: \_\_\_\_\_

## APPENDIX C

---

### SAMPLE REPORT FORM

COMPANY \_\_\_\_\_

#### WEB STRAP INSPECTION REPORT (FORM NO. L6)

SHEET 1 OF 1

Date: \_\_\_\_\_

S/N: \_\_\_\_\_

| ITEM NO. | DESCRIPTION OF DAMAGE TO LOOK FOR  | PASS | NEEDS ATTN. | COMMENTS |
|----------|--|------|-------------|----------|
| L6.1     | Web Strap (entire length):<br>Melting/charring, acid/caustic burns, weld spatter, broken stitching, cuts and tears, damaged eyes, abrasive wear, knots, narrowing. |      |             |          |
| L6.2     | Web Strap- sections in contact with saddles, equalizer sheaves, other sheaves where travel is limited:<br>Rapid deterioration, wear.                               |      |             |          |
| L6.3     | Web Strap – sections at or near terminal ends:<br>Broken threads, cuts, and rapid deterioration and wear.  |      |             |          |
| L6.4     | Web Strap – sections subject to reverse bending:<br>Rapid deterioration, wear.   |      |             |          |
| L6.5     | Web Strap – Sections that are hidden normally, such as those which pass over sheave:<br>Rapid deterioration, wear.   |      |             |          |

Signature and Date of Inspector: \_\_\_\_\_

Signature and Date of Supervisor: \_\_\_\_\_

## NOTES

---

## NOTES

---

## NOTES

---



